

## HYDRA LED UNDERWATER LIGHT



12V AC/DC input voltage is suitable for any underwater applications. Available in stainless steel.

### Features

- Replaceable LED light source
- Tempered convex glass
- Safe low voltage operation
- Anti-corrosion fixture
- Replaceable waterproof enclosure rated MR16s sold separately

### Applications

Landscape | Water Features | Underwater



### Specifications

Voltage	12-24V DC (MR16 Bulb)	
Wattage	5W	7W
Lumens	550	800
Color Temp	2700K	2700K / 3000K
# of LEDs	6 Samsung LEDs	
CRI	>85	
Lifespan	+50,000 hours	
Beam Degree	40°	
Working Temp	-20°C~+40°C (-4~104°F)	
IP	65	
Dimmable	No	
Housing	Stainless Steel	
Wire Length	16.5' (5M)	
Dimensions	Trim Ø3 <sup>3</sup> / <sub>4</sub> " (96mm), Housing H3 <sup>3</sup> / <sub>8</sub> " (85mm), Base Ø3 <sup>3</sup> / <sub>8</sub> " (85mm) x H2" (49mm)	
Warranty	3-year	

### Housing



Stainless Steel

### Dimensions

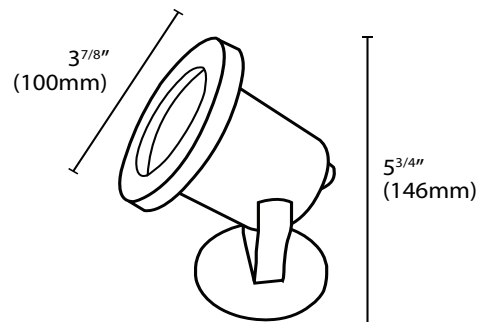



## ORDERING CODES

MR16 LED bulb and Spotlight housing require separate ordering codes.

### MR16 LED Bulb

Choose a MR16 bulb color temperature.





Image	Code	Product	Description
	LS-MR16-W-5W-27K	5W MR16 LED Bulb	12V AC/DC, 5W, L2 x Ø2" (L50 x Ø50mm)
	LS-MR16-W-7W-27K	7W MR16 LED Bulb	12V AC/DC, 7W, L2 x Ø2" (L50 x Ø50mm)
	LS-MR16-W-7W-3K		



### Spotlight Housing

Image	Code	Product	Description
	LS-UW-MR	Underwater Rated Housing	Stainless steel. Safe low voltage operation.





### Accessories

Image	Product	Code	Description
	100' Outdoor Wire	LS-OW-16-2-100	Outdoor wire for led lights. 16-2 AWG
	Outdoor Rated Marettes	LS-GEL-MAR	Outdoor rated, gel filled marettes ensure secure electrical connections in outdoor and wet conditions. Pack of 2.

### Power Supplies

Image	Code	Voltage	Output Power	Class II	Dimmable Specs
<b>Dimmable</b>					
	LS-12V-30D-MLT-CV	12V	Max. 30W	√	Triac/Phase. 0-10V, 1-10V, Potentiometer, 10V PWM 5 in 1 dimming
	LS-12V-60D-MLT-CV	12V	Max. 60W	√	Triac/Phase. 0-10V, 1-10V, Potentiometer, 10V PWM 5 in 1 dimming

## More Power Supplies

Image	Code	Voltage	Output Power	Class II	Dimmable Specs
<b>Non-Dimmable</b>					
	LS-12V-30W-O-CV	12V	Max. 30W	√	N/A
	LS-12V-60W-O-CV	12V	Max. 60W	√	N/A
	LS-12V-96W-O-CV	12V	Max. 96W	x	N/A
	LS-12AC-200W-LPS	12V AC	Max. 200W	x	Non dim outdoor transformer with built in photocell and timer